

EWELLIX

MAKERS IN MOTION

Miniature profile rail guides - LLM



Contents

Product description.....	4
Design	5
Components and material specifications.....	5
Application examples.....	6
Product features.....	7
Rails.....	7
Carriages.....	7
Preload and stiffness	7
General technical information	8
Accuracy	8
Load carrying capacity	9
Product range	10
Carriage dimensions.....	10
Rail dimensions.....	11
Mounting instruction and maintenance	12
Mounting details	12
Lubrication	13
Accessories.....	13
LZM miniature slide.....	14
Product range	16
Special designs tailored to customer requirements	18
Ordering key LLM	19
Ordering key LZM	20

The heritage of innovation

Ewellix is a global innovator and manufacturer of linear motion and actuation solutions. Today, our state-of-the-art linear solutions are designed to increase machine performance, maximise uptime, reduce maintenance, improve safety and save energy.

Technology leadership

Our journey began **over 50 years** ago as part of the SKF Group, and our history with SKF provided us with the **expertise to continuously develop new technologies** and use them to create cutting edge products that offer our customers a competitive advantage.

In 2019, we became independent from SKF and changed our name to Ewellix. We are proud of our heritage. This gives us a unique foundation on which to build an agile business with engineering excellence and innovation as our core strengths.

Global presence and local support

With our **global** presence, we are uniquely positioned to deliver **standard components and custom-engineered solutions**, with full technical and applications support around the world. Long standing relationships with our distributor partners allow us to support customers in a variety of different industries. At Ewellix, we don't just provide products; **we engineer integrated solutions** that help customers realise their ambitions.



1 200 employees



16 sales units



10 factories

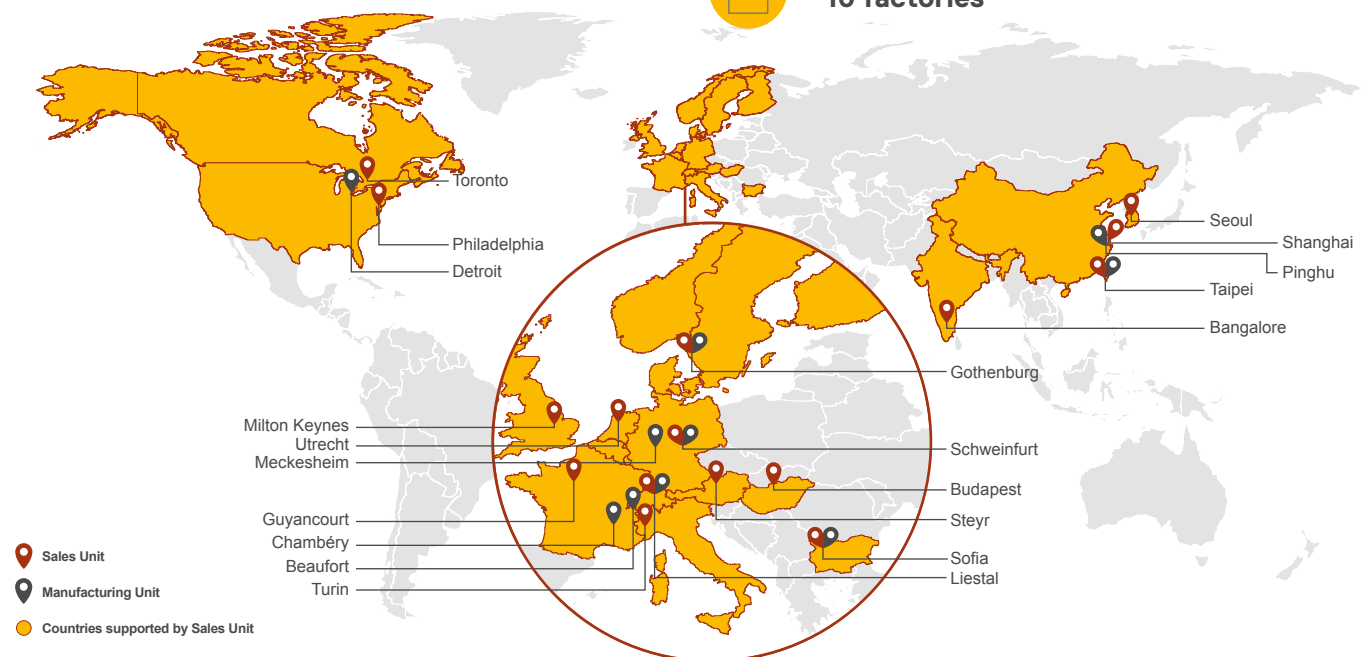

Trusted engineering expertise

Our industry is in motion; pushing towards solutions that reduce environmental impact and leverage new technology. We provide technical and manufacturing expertise to overcome our customers' challenges.

Engineering for the future

We work in a **wide range of industries**, where our solutions provide key functionality for business critical applications.

For the **medical industry**, we provide precision components for use in core medical equipment.

Our unparalleled understanding of **industrial automation** systems is based on decades of research into advanced automation components and techniques.

Our deep knowledge of **mobile machinery** provides powerful and reliable electromechanical solutions for the harshest conditions. In an **industrial distribution** setting, we supply linear expertise to our partners, empowering them to serve customers with greater efficiency.

We offer excellence

We have a **unique understanding of linear equipment** and how it's integrated in customers' applications to provide the best performance and machine efficiency.

We assist our customers by creating equipment that runs faster, longer and safer and that is sustainable.

We provide a wide variety of **linear motion components** and electromechanical actuators for equipping any automation application, helping our customers **reduce its footprint, energy use and maintenance**.

We push for lower energy consumption that **increases productivity and reduces the environmental impact**.

Actuation systems



Ball and roller screws



Linear guides and systems

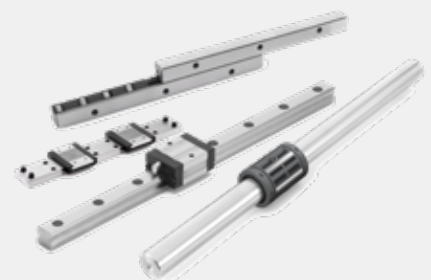

Product description

In response to the market trend for increased performance with a minimum of mounting space, Ewellix has extended its product range by a miniature profile rail guide. The close cooperation with numerous customers combined with Ewellix's experience has resulted in a miniature rail guide design that sets new standards.

Ewellix offers its customers an excellent technical advisory service on the spot as well as a vast modular range for the performance increase of machines and installations. In total Ewellix offers seven rail sizes and fourteen different types of carriages.

Miniature profile rails are universally applicable and preferably used in automation technology, electronics production, medical engineering and the pneumatic industry (↳ [Application examples, page 6](#)).



Design

Types of rails, carriages and systems

Size		LLMHS_TA Standard	LLMHS_LA Standard, long	LLMWS_TA Wide	LLMWS_LA Wide, long
-	-	-	-	-	-
7	Rail	LLMHR 7	LLMHR 7	-	-
	Carriage	LLMHC 7 TA	LLMHC 7 LA	-	-
	System	LLMHS 7 TA	LLMHS 7 LA	-	-
9	Rail	LLMHR 9	LLMHR 9	LLMWR 9	LLMWR 9
	Carriage	LLMHC 9 TA	LLMHC 9 LA	LLMWC 9 TA	LLMWC 9 LA
	System	LLMHS 9 TA	LLMHS 9 LA	LLMWS 9 TA	LLMWS 9 LA
12	Rail	LLMHR 12	LLMHR 12	LLMWR 12	LLMWR 12
	Carriage	LLMHC 12 TA	LLMHC 12 LA	LLMWC 12 TA	LLMWC 12 LA
	System	LLMHS 12 TA	LLMHS 12 LA	LLMWS 12 TA	LLMWS 12 LA
15	Rail	LLMHR 15	LLMHR 15	LLMWR 15	LLMWR 15
	Carriage	LLMHC 15 TA	LLMHC 15 LA	LLMWC 15 TA	LLMWC 15 LA
	System	LLMHS 15 TA	LLMHS 15 LA	LLMWS 15 TA	LLMWS 15 LA



Components and material specifications

- Structure:**
Four-point contact ball recirculation system with identical load angles and 2 ball recirculation paths per carriage for unlimited stroke
- Range:**
Four different types (7, 9, 12, 15) comprising different widths and carriage lengths
- Rail material:**
Stainless steel 1.4034, 1.4037 or equivalent
- Carriage material:**
Stainless steel 1.4034, 1.4037 or equivalent with return zones of POM
- Ball material:**
Stainless steel 1.3541
- Sealing material:**
Elastolan
- Temperature range:**
from -20 °C up to +80 °C
- Speed:**
up to 3 m/s max
- Acceleration:**
up to 80 m/s² max (preloaded system)
- Accuracy:**
2 accuracy classes (P5, P1)
- Stiffness:**
3 standard preload classes (T0, T1, T2)

Application examples

Electronics

PCB drilling and routing machine

A flat-format and weight-saving design enables small machine dimensions. High power density results in shorter processing times.

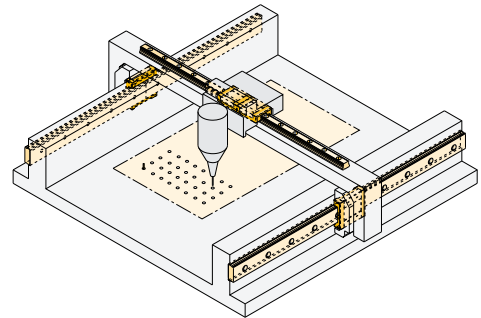

Automation technology

Pick-and-place manipulators

A low-mass guidance system coupled with aluminium profiles permits faster sequences of motion and higher cycle rates.

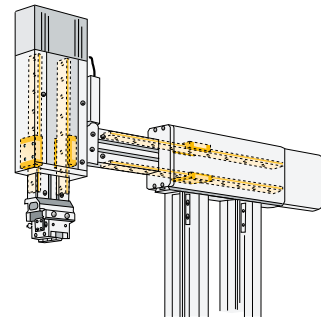

Medical equipment

Optical instruments

Ease of movement and corrosion resistant materials ensure reliability in everyday use.

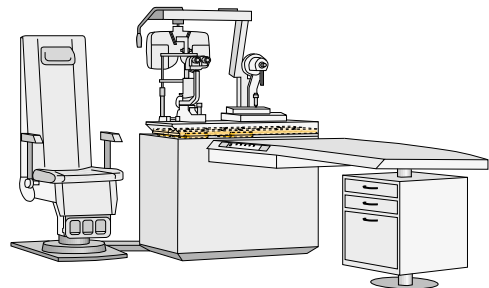

Pneumatic industry

Compact piston rod cylinder

High rigidity and load carrying capacity designed for long service life in "short stroke applications" (typical for pneumatic applications).

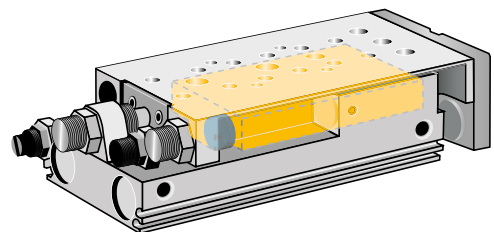

Product features

Maximum utilisation of mounting space

The compact design of the Ewellix miniature profile rail guides permits maximum performance on a minimum of mounting space. Dimensions and weights of machines and installations can be further reduced.

Performance

For improved machinery performance, maximum speeds and accelerations under loads acting in all directions are possible. This permits more efficient processes and the reduction of cycle times.

Reliability

More than 90 years of Ewellix experience with rolling bearing geometry guarantee long product life. Maintenance intervals are extended and the service life of machines and installations is increased.

Resistance

The use of stainless steel in combination with plastic components makes these guides universally applicable. The reliability in application engineering is increased and risks are eliminated.

Rails

The rails are ground on all faces. The maximum rail lengths per piece are shown in the (→ **table 1**). Ewellix supplies the rails in lengths according to customer requirements. The distance measurement E (see Illustration → **page 8**) is manufactured symmetrically, depending on the rail length. Upon request, Ewellix can also supply special rails to customer drawings.

Carriages

A wide range of 14 different types of carriages, each available in three preload classes (→ **table 2**) and with a choice between sealed and open types, permits optimum system designs tailored to the respective requirement profile.

Preload and stiffness

The determination of an appropriate preload renders the miniature profile rail guide suitable for widely varying operating conditions and changes the stiffness of the overall system. Ewellix recommends systems in T0 preload class for applications with constant load and low friction. For applications characterised by shock loads, vibration and alternating loads or torques, it is advisable to select a preloaded system (T1) and a (T2) system should be chosen for high torques and high stiffness.

Table 1

Rail designation	Maximum rail length per piece*
LLMHR 7	1 000 mm
LLMHR 9 / LLMWR 9	1 000 mm
LLMHR 12 / LLMWR 12	1 000 mm
LLMHR 15 / LLMWR 15	1 000 mm

* For rail length > 1 000 mm, please contact Ewellix.

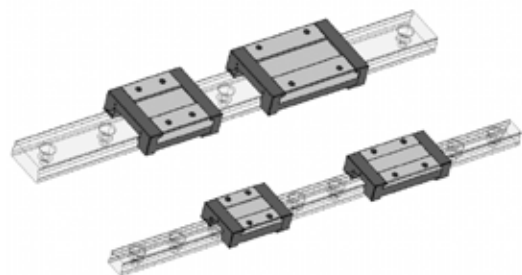
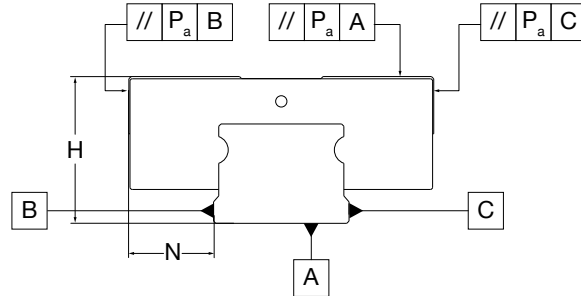

Table 2

Preload class	Characteristics
T0	Clearance
T1	Zero clearance to light preload
T2	Preloaded system

General technical information

Accuracy



Precision class ¹⁾	Tolerances of		Difference in dimension H and N on one rail or for paired systems (suffix W2)	
	H μm	N	ΔH max μm	ΔN max
P5	±20	±25	15	15
P1	±10	±15	7	7

¹⁾ Related to the ideal centre of the carriage. Each dimensions is derived from the mean value of two measured points with identical centre distance.

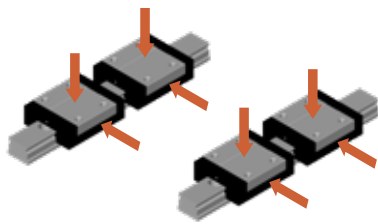

For any combination of carriages and rails

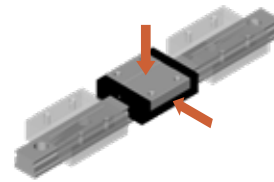

For different carriages on the same rail position

Parallelism

Diagram 1

P_a deviation in parallelism [μm] for N and H

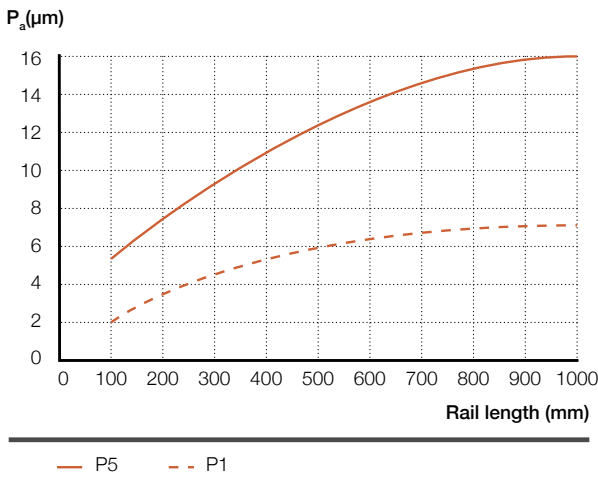

Distance tolerance

Fig 1

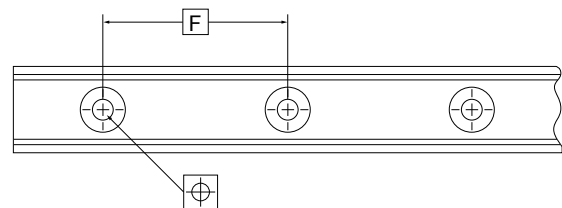

Position tolerance of rail attachment holes

\oplus \ominus 0,3

Load carrying capacity

Static load rating C_0

The static load rating C_0 is the load which corresponds to an arithmetical Hertzian Pressure of 4 200 MPa between raceway and balls. This pressure produces a permanent deformation of approximately 0,0001 of the ball diameter.

Static moments “ M_A , M_B , M_C ”

The permissible static moments correspond to a moment load that produces the same permanent deformation as in the static load rating C_0 .

Load direction

Ewellix miniature profile rail guides are designed to accommodate loads in all directions.

Dynamic load rating C

The dynamic load rating C is the constant load which gives a theoretical system life of 100 000 m of travel with a certainty of 90%.

Life calculation

The life of a profile rail guide is defined as the total linear distance travelled before the appearance of the first signs of material fatigue on the raceways or rolling elements.

Both in laboratory trials and in practice it is found that the life of apparently similar rail guides under completely identical operating conditions can differ. Calculation of the requisite bearing size therefore requires a clear statistic definition of the term bearing life. All references to dynamic load rating of profile rail guides apply to the basic rating life as covered by the ISO definition, in which life is understood as that operating period reached or exceeded by 90% of a large group of identical bearings. The Ewellix life calculation is based on 100 000 metres of travel. Other calculation models assume merely 50 000 metres of travel. In such cases, the dynamic load ratings must be divided by a factor of 1,26 to ensure comparability with the Ewellix values.

Where the stroke length and frequency are constant it is often easier to calculate the basic rating life in hours of operation using the equation:

$$L_{10} = \left(\frac{C}{P} \right)^3$$

where

- L_{10} : basic rating life, 105 m
- C : dynamic load rating, N
- P : equivalent dynamic bearing load, N

$$L_{10h} = \frac{50\,000\,000}{s \cdot \eta \cdot 60} \left(\frac{C}{P} \right)^3$$

where

- L_{10h} : basic rating life, hours of operation
- s : stroke, mm
- n : frequency of stroke, min^{-1} (number of movements from one end position to the other end and back again)

Permissible operating conditions

Permissible maximum load

DIN 636, Part 2, stipulates that the calculation of bearing life is valid only when the equivalent dynamic loading of a profile rail guide does not exceed 0,5 C . Any higher loading leads to an imbalance of stress distribution which can have a negative effect on bearing life. Where such conditions prevail, the user should turn to Ewellix for recommendations and advice on bearing life calculation.

Requisite minimum load

In order to assure slip-free running of profile rail guides, they must be subjected to a certain minimum load. The general guideline is a minimum value of $P = 0,001 C$. The minimum load is of special importance in profile rail guides which operate at high speed or with high acceleration. In such cases, the inertia forces of the balls as well as the rolling friction in the lubricant can have an adverse effect on the rolling conditions in the guide and can lead to damaging slip conditions between the balls and raceways.

Product range

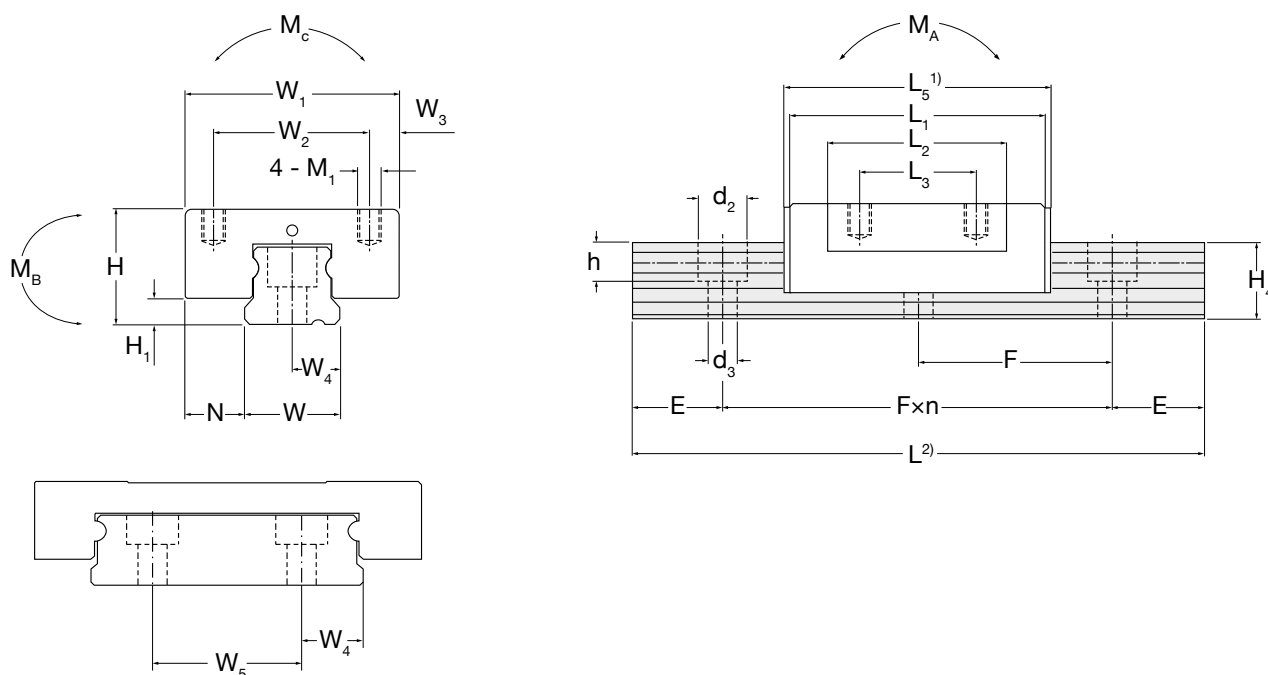

1) For carriage with seals
2) Tolerance of rail length ±1mm

Carriage dimensions

Designation	Dimension											Weight Kg
	H mm	W ₁	W ₂	W ₃	L ₁	L ₂	L ₃	L ₅ ¹⁾	M ₁	N	H ₁	
LLMHS 7 TA	8	17	12	2,5	22	16	8	23,5	M2×2,5	5	1,5	0,01
LLMHS 7 LA	8	17	12	2,5	29,5	23,5	12	31	M2×2,5	5	1,5	0,02
LLMHS 9 TA	10	20	15	2,5	30	21,5	10	32	M3×3	5,5	2	0,02
LLMHS 9 LA	10	20	15	2,5	38,5	30	15	40,5	M3×3	5,5	2	0,03
LLMWS 9 TA	12	30	21	4,5	36,5	28	12	38,5	M3×3	6	2	0,04
LLMWS 9 LA	12	30	23	3,5	48,5	40	24	50,5	M3×3	6	2	0,06
LLMHS 12 TA	13	27	20	3,5	33	23	15	36	M3×3,5	7,5	3	0,03
LLMHS 12 LA	13	27	20	3,5	45	35	20	48	M3×3,5	7,5	3	0,06
LLMWS 12 TA	14	40	28	6	42,5	32,5	15	45,5	M3×3,5	8	3	0,08
LLMWS 12 LA	14	40	28	6	56	46	28	59	M3×3,5	8	3	0,11
LLMHS 15 TA	16	32	25	3,5	41,5	29,5	20	44,5	M3×4	8,5	4	0,06
LLMHS 15 LA	16	32	25	3,5	57,5	45,5	25	60,5	M3×4	8,5	4	0,1
LLMWS 15 TA	16	60	45	7,5	54	42	20	57	M4×4,5	9	4	0,15
LLMWS 15 LA	16	60	45	7,5	71	59	35	74	M4×4,5	9	4	0,22

Rail dimensions

Designation	Dimension				$d_3 \times d_2 \times h$	E_{\min}	F	Weight kg/m	Basic load rating		Static moments		
	H_4 mm	W	W_4	W_5					C N	C_0	M_A Nm	M_B	M_C
LLMHS 7 TA	4,8	7	3,5	-	2,5×4,5×2,5	5	15	0,21	860	1 670	4,9	4,9	5,2
LLMHS 7 LA	4,8	7	3,5	-	2,5×4,5×2,5	5	15	0,21	1 400	2 700	7	7	9
LLMHS 9 TA	6,5	9	4,5	-	3,5×6×3,5	5	20	0,36	1 850	3 130	11,2	11,2	13,2
LLMHS 9 LA	6,5	9	4,5	-	3,5×6×3,5	5	20	0,36	2 295	4 270	20,1	20,1	17,9
LLMWS 9 TA	7,5	18	9	-	3,5×6×4,5	5	30	0,98	2 200	3 800	14,2	14,2	30,4
LLMWS 9 LA	7,5	18	9	-	3,5×6×4,5	5	30	0,98	2 820	5 680	30,2	30,2	45,1
LLMHS 12 TA	8,8	12	6	-	3,5×6×4,5	5	25	0,63	2 550	4 000	15	15	21,7
LLMHS 12 LA	8,8	12	6	-	3,5×6×4,5	5	25	0,63	3 470	6 225	34,5	34,5	33,8
LLMWS 12 TA	8,8	24	12	-	4,5×8×4,5	5	40	1,6	3 300	5 780	30	30	69
LLMWS 12 LA	8,8	24	12	-	4,5×8×4,5	5	40	1,6	4 150	8 000	55,8	55,8	95,6
LLMHS 15 TA	10,8	15	7,5	-	3,5×6×4,5	5	40	1,12	2 880	5 390	21	21	40,2
LLMHS 15 LA	10,8	15	7,5	-	3,5×6×4,5	5	40	1,12	4 670	8 720	57	57	67,6
LLMWS 15 TA	10,8	42	9,5	23	4,5×8×4,5	5	40	3,25	3 890	7 060	40	40	148
LLMWS 15 LA	10,8	42	9,5	23	4,5×8×4,5	5	40	3,25	5 830	10 600	94	94	225

Mounting instruction and maintenance

Mounting details

Fig 2

Permissible height deviation in transverse direction H_a

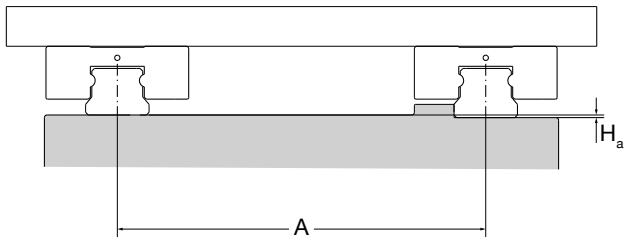

$$H_a = A \cdot Z$$

where

H_a : permissible height deviation (mm)

A: distance of rails (mm)

Z: calculation factor T_0 $3,0 \cdot 10^{-4}$

T_1/T_2 $1,5 \cdot 10^{-4}$

Fig 3

Permissible height deviation in longitudinal direction H_b

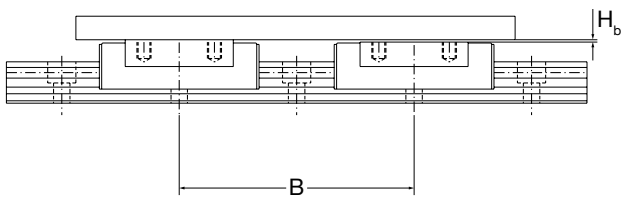

$$H_b = B \cdot 7 \cdot 10^{-5}$$

where

H_b : permissible height deviation (mm)

B: distance of carriages (mm)

Fig 4

Ideal mounting arrangement

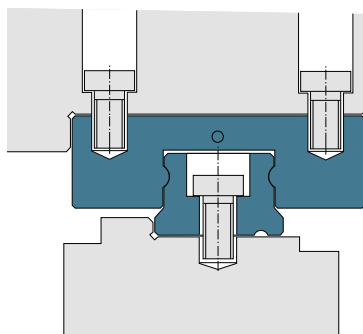

The **fig. 4** shows the ideal mounting arrangement for miniature profile rail guides. Carriage and rail can be mounted at both sides, but their datum planes should be on the same side of the system. To ensure a neat abutment to the adjacent edges, these should feature a relief fillet.

Table 3

Tightening torque of fixing bolts

Thread size	Maximum tightening torque Ncm
M2	32
M3	110
M4	260
M3	510

The **table 3** shows the maximum tightening torques for fixing bolts depending on the thread size.

Lubrication

The relubrication intervals depend on the environmental conditions and the magnitude and type of load!
 As the manufacturer is not familiar with the respective individual operating conditions, only tests carried out by the user or close observation can provide certainty about the appropriate relubrication intervals.
 Ewellix miniature profile rails are pregreased and are thus ready for use when delivered. The individual carriages can be lubricated through lubrication holes at the faces (↳ Fig. 5). Here, the relubrication intervals depend on the distance travelled as well as the cycles and environmental conditions.

Carriages mounting and dismounting

For dismounting the system premounted by Ewellix, please observe the following instructions (↳ Fig. 6):

- Remove the end-stop (B) from the rail.
- Position side (1) of the mounting rail (A) to the rail (2) so that there is no misalignment or gap between rail and mounting rail.
- Slide the carriage (C) from the rail to the mounting rail and keep both rails in position while doing so.

For mounting the carriage onto the rail, please proceed in reverse order.

Attention: Please always use the enclosed mounting rail as the ball retention inside the carriage is not guaranteed otherwise.

Accessories

In addition to the plastic end-stop which is fastened in the first and last rail hole, there is also an option for a steel end-stop that can be mounted at any place beside the holes (↳ Fig. 7). Order suffix – M.

Attention:
 This does not serve as a limit stop.

Fig 5

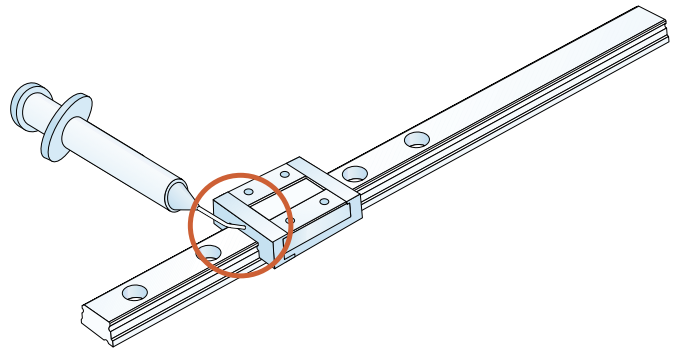

Table 4

Order designation	Size	
VM LLM 12	Standard 7, 9, 12,	Wide series 9 W, 12 W
VM LLM 15	15	15W

Fig 6

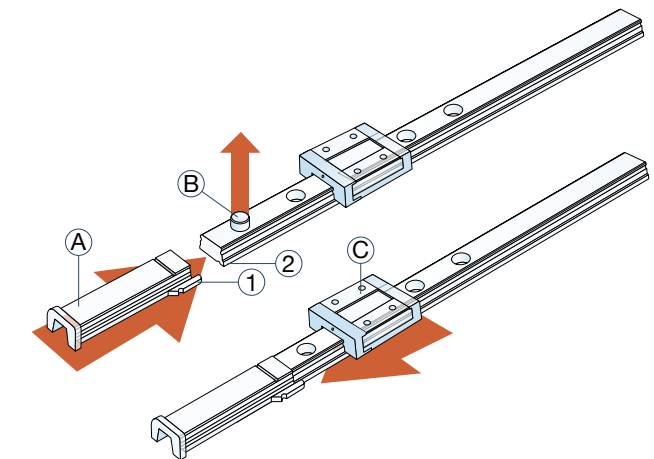
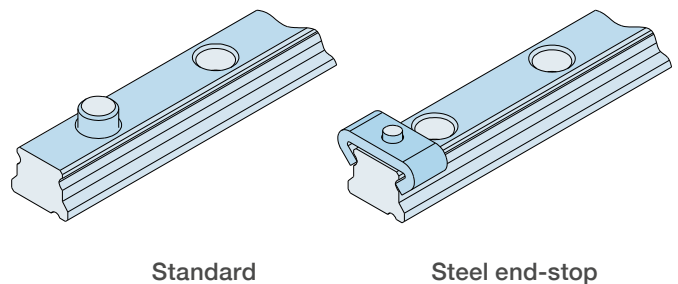

Fig 7



Standard

Steel end-stop

LZM miniature slide

With the LZM miniature slide product range, Ewellix offers the ideal solution for linear motion applications with short strokes and compact boundary dimensions. The use of miniature slides has significantly increased in medical applications, measurement technologies and micro mechanics and assembly.

The various LZM miniature slide components are designed to meet the highest precision standards. LZM miniature slides feature high running accuracy and smooth motion, and are manufactured with all-stainless-steel components. The maximum value for parallelism between the raceways and the mounting surface is 3 µm. Optimized hardness enables long service life and high performance within compact boundary dimensions.

Ease of installation is another positive feature of LZM miniature slides. Unlike crossed roller systems using 4 rails and 2 cages to be assembled on the production floor, the LZM miniature slide provides a complete slide that can simply be bolted into place without the use of precision devices to set preload.

Customized miniature slides are also possible, and Ewellix will modify existing designs to meet specific technical requirements. Wide versions of LZMs for higher torque loads, comparable with wide miniature profile rail guides LLMWS, can also be supplied on request.

Applications:

- Pneumatics
- Semi-conductor manufacturing
- Medical
- Micro- and electronics assembly
- Measurement applications
- Fibre optics

Advantages:

- Compact design
- High load capacity
- Very good running accuracy
- Smooth running
- High rigidity
- Easy assembly

Ordering example

- LZMHS 9 – 26
(P5, T0 as standard – no need to specify)
- LZMHS 9 – 26 T2 P1



LZM data

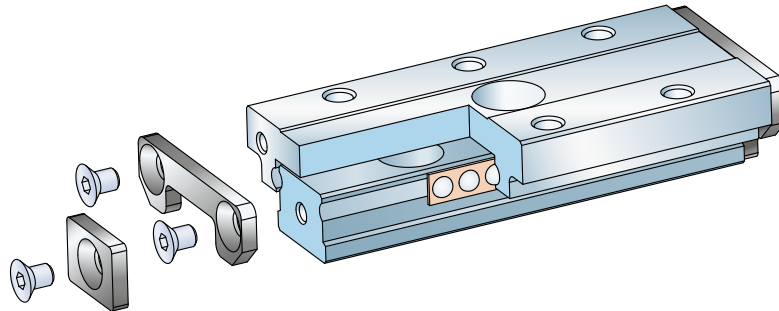

Technical data

Design	Four point contact with identical load angles
Standard range	Four sizes: 7, 9, 12 and 15
Optional range	Wide versions for 9, 12 and 15
Operating temperature	-20 up to +80 °C
Max. speed	3 m/s
Max. acceleration	80 m/s ² (for preloaded LZMs)
Preload classes	T0 = light clearance; Standard T1 = zero clearance to light preload T2 = preloaded
Precision classes	P5 = standard P1 = high
Lubrication	Slides are pre-lubricated with "Paraliq P460"

Material specifications

Carriage and rail	Steel 1.4034 / 1.4037
Balls	Steel 1.3541
End pieces	Plastic
Cage	Plastic

Dimensional tolerance of H

Precision class	mm
P5	+/-0,02
P1	+/-0,01

Product range

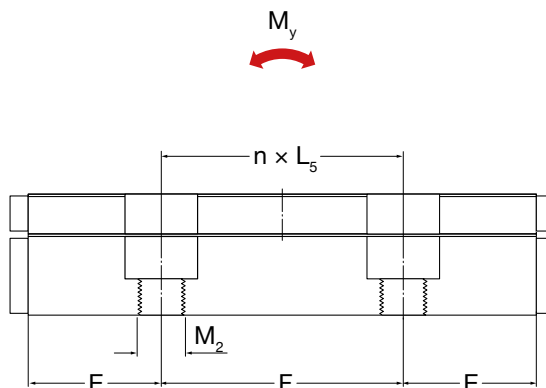
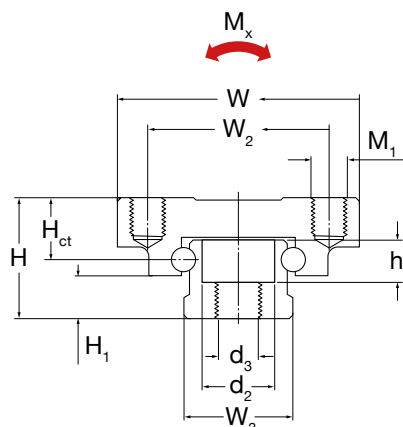

Designation	Dimension											
	L	L ₁	L ₂	L ₄	n x L ₅ ¹⁾	W	W ₂	W ₃	H	H ₁	M ₁ x depth	Number of threads M ₁
	mm											
LZM HS 7 – 26	26	5	8	29	–	17	12	7	8	2,35	M2x2,5	6
LZM HS 7 – 34	34	5	8	37	0	17	12	7	8	2,35	M2x2,5	8
LZM HS 7 – 50	50	5	8	53	30	17	12	7	8	2,35	M2x2,5	12
LZM HS 7 – 66	66	5	8	69	30	17	12	7	8	2,35	M2x2,5	16
LZM HS 9 – 32	32	9,5	13	35	–	20	15	9	10	3,55	M3x3	4
LZM HS 9 – 42	42	8	13	45	0	20	15	9	10	3,55	M3x3	6
LZM HS 9 – 55	55	8	13	58	20	20	15	9	10	3,55	M3x3	8
LZM HS 9 – 81	81	8	13	84	2x20	20	15	9	10	3,55	M3x3	12
LZM HS 9 – 94	94	8	13	97	3x20	20	15	9	10	3,55	M3x3	14
LZM HS 12 – 37	37	11	15	40	–	27	20	12	13	4,7	M3x3,5	4
LZM HS 12 – 51	51	10,5	15	54	0	27	20	12	13	4,7	M3x3,5	6
LZM HS 12 – 66	66	10,5	15	69	25	27	20	12	13	4,7	M3x3,5	8
LZM HS 12 – 96	96	10,5	15	99	50	27	20	12	13	4,7	M3x3,5	12
LZM HS 12 – 126	126	10,5	15	129	3x25	27	20	12	13	4,7	M3x3,5	16
LZM HS 15 – 52	52	16	20	56	–	32	25	15	16	6	M3x4	4
LZM HS 15 – 85	85	12,5	20	89	0	32	25	15	16	6	M3x4	8
LZM HS 15 – 105	105	12,5	20	109	40	32	25	15	16	6	M3x4	10
LZM HS 15 – 165	165	12,5	20	169	80	32	25	15	16	6	M3x4	16

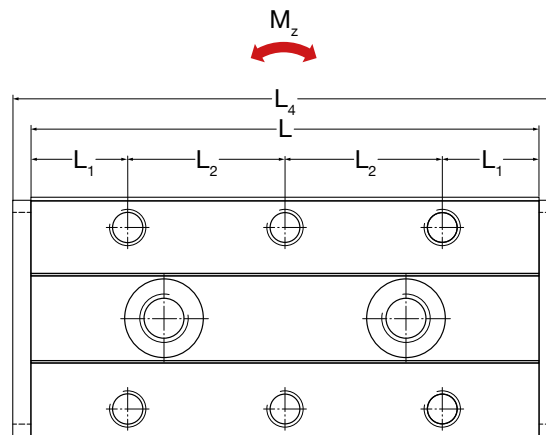

E	F	$d_3 \times d_2 \times h$	M_2	Number of threads M_2	Max. stroke	C	C_0	M_{yCo} / M_{zCo}	M_{xCo}	H_{ct}
	mm		–		mm	N		Nm		mm
5,5	15	2,5×4,5×2,5	M3	2	24	700	1 100	3,5	6	4,62
9,5	15	2,5×4,5×2,5	M3	2	34	900	1 400	5,5	7	4,62
10	15	2,5×4,5×2,5	M3	3	50	1 100	2 000	12	10	4,62
10,5	15	2,5×4,5×2,5	M3	4	66	1 400	2 700	21	14	4,62
6	20	3,5×6,5×3,5	M4	2	28	1 200	1 800	7	12	5,12
11	20	3,5×6,5×3,5	M4	2	40	1 400	2 100	11	15	5,12
7,5	20	3,5×6,5×3,5	M4	3	54	1 900	3 400	18	19	5,12
10,5	20	3,5×6,5×3,5	M4	4	78	2 500	4 900	43	29	5,12
7	20	3,5×6,5×3,5	M4	5	92	2 700	5 500	57	33	5,12
6	25	3,5×6,5×4,5	M4	2	32	2 200	3 300	11	21	6,5
13	25	3,5×6,5×4,5	M4	2	47	2 600	4 300	22	28	6,5
8	25	3,5×6,5×4,5	M4	3	62	3 000	5 300	36	36	6,5
10,5	25	3,5×6,5×4,5	M4	4	95	3 800	7 200	76	52	6,5
13	25	3,5×6,5×4,5	M4	5	122	4 700	9 700	131	68	6,5
6	40	3,5×6,5×4,5	M4	2	50	2 800	3 900	25	42	7,65
22,5	40	3,5×6,5×4,5	M4	2	80	4 600	7 800	73	70	7,65
12,5	40	3,5×6,5×4,5	M4	3	102	5 100	9 100	106	84	7,65
22,5	40	3,5×6,5×4,5	M4	4	162	7 300	15 000	264	131	7,65

Special designs tailored to customer requirements

Different fastening holes (stepped holes) in terms of size and depth of holes relative to each other (↳ Fig. 8).

Fig 8

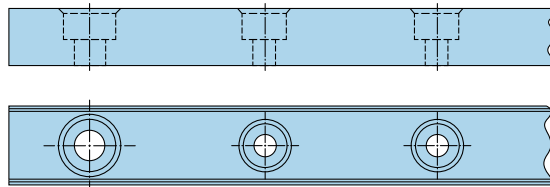

Variable hole distances (↳ Fig. 9).

Fig 9

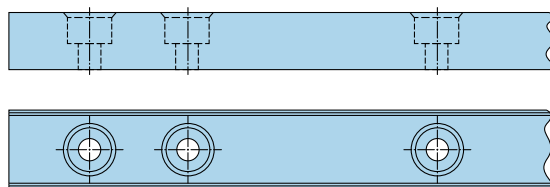

Blind holes and threads, through holes or through threads (↳ Fig. 10).

Fig 10

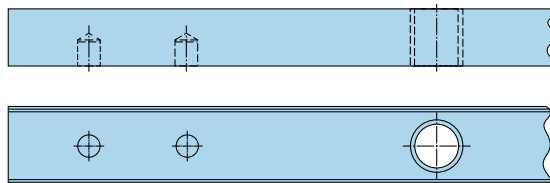

Without fixing bores for gluing of rail (↳ Fig.11).

Fig 11

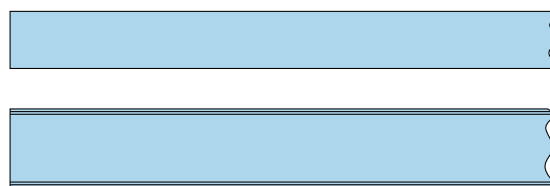

Special design with limited stroke (without ball recirculation) according to customer request (↳ Fig. 12).

Fig 12

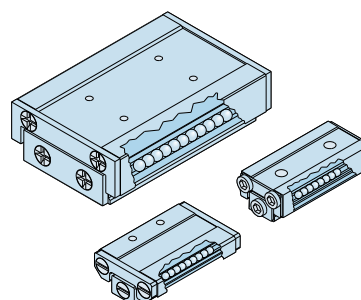

Ordering key LLM

L L M H S 1 2 T A R 2 T O - 7 0 0 P 1 W 2 - M

Miniature profile rail

Rail

- H Standard system
- W Wide rail

Type code

- S System
- C Carriage
- R Rail

Size

7, 9, 12, 15

Carriage type

- TA Standard carriage
- LA Long carriage

Seals

- Carriage without seals
- R Carriage with seals

Number of carriages per rail

Preload

- T0 Clearance
- T1 Zero clearance to light preload
- T2 Preloaded system

Rail length in 1 mm increments

Precision class

- P5 Standard
- P1 High

Rail system

- W1 Single rail system
- W2 Parallel rail system

End-stop

- Plastic end-stop
- M Steel end-stop

Ordering key LZM

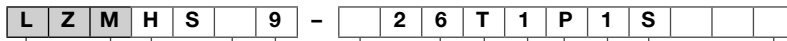

Miniature slide _____

Rail _____

- H Standard system
- W Wide rail ¹⁾

Size _____

7, 9, 12, 15

Length L _____

Standard length, selected from product range tables (L→ pag. 14) or Customised length, in 1 mm increments ¹⁾

Preload _____

- T0 Light clearance; standard - no need to specify
- T1 Zero clearance to light preload
- T2 Preloaded system

Precision class _____

- P5 Standard - no need to specify
- P1 High

Stroke in mm _____

Needed only for customised LZM,
For standard lengths - no need to specify

¹⁾ on request.

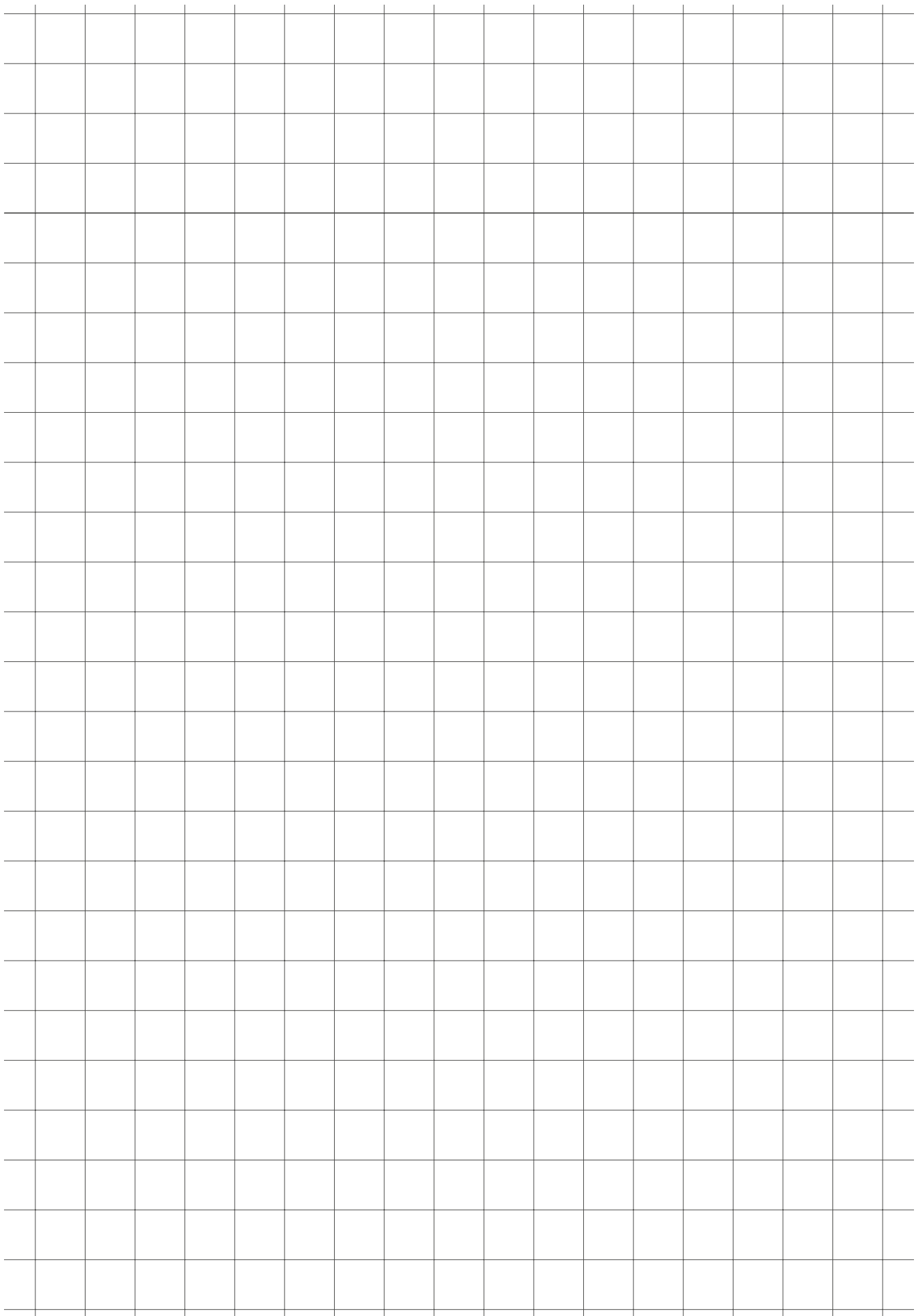

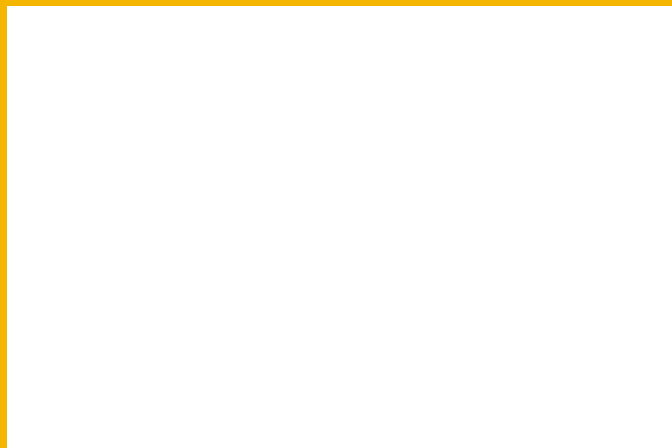

ewellix.com

© Ewellix

All contents of this publication are the property of Ewellix, and may not be reproduced or given to third parties (even extracts) without permission. Although great care has been taken in the production of this catalog, Ewellix does not take any responsibility for damage or other loss resulting from omissions or typographical errors. The photo may differ slightly in appearance from the actual product. Due to continuous improvements being made in our products, the product's appearance and specifications are subject to change without notice.

PUB IL-06003-EN-October 2019

Certain image(s) used under license from Shutterstock.com.
SKF and SKF logo are trademarks of the SKF Group